

Member of



**INSTITUTO DE CIENCIAS
DE LA CONSTRUCCIÓN
EDUARDO TORROJA**

C/ Serrano Galvache, 4. 28033 Madrid (Spain)
Tel.: (+34) 91 302 0440 www.ietcc.csic.es
gestiondit@ietcc.csic.es
dit.ietcc.csic.es

European Technical Assessment

ETA 20/0046
18/09/2025

English translation prepared by IETcc. Original version in Spanish language

General Part

Technical Assessment Body issuing the European Technical Assessment:
Instituto de Ciencias de la Construcción Eduardo Torroja (IETcc)

Trade name of the construction product

Screw anchor THE

Product family to which the construction product belongs

Screw anchor of sizes 6, 8, 10, 12, 14, 16 and 18 for use in concrete.

Manufacturer

Index - Técnicas Expansivas S.L.
Segador 13
26006 Logroño (La Rioja) Spain.
website: www.indexfix.com

Manufacturing plant

Index plant 2

This European Technical Assessment contains

36 pages including 3 annexes which form an integral part of this assessment.

This European Technical Assessment is issued in accordance with Regulation (EU) No 305/2011, on the basis of

European Assessment Document EAD 330232-01-0601 "Mechanical Fasteners for use in concrete", ed. December 2019

This ETA replaces

ETA 20/0046 revision 6 dated 28/04/2025



Translations of this European Technical Assessment in other languages shall fully correspond to the original issued document.

Communication of this European Technical Assessment, including transmission by electronic means, shall be in full. However, partial reproduction may be made, with the written consent of the issuing Technical Assessment Body. Any partial reproduction has to be identified as such



SPECIFIC PART

1. Technical description of the product

The Index THE screw anchors are comprised of a body with a head. The head diameter is larger than the diameter of the anchor and is formed with a variety of serrations undersize. The anchor body is formed with threads running most of the length of the anchor body. The anchor is installed in a predrilled hole with an impact wrench or torque wrench. The anchor threads cut into the concrete on the side of the hole and interlock with the base material during the installation.

The Index screw anchor THE is a fastener made of carbon steel of sizes 6, 8, 10, 12, 14, 16 and 18. The Index screw anchor TXE is a fastener made of stainless steel of sizes 6, 8, 10 and 12.

Product and installation descriptions are given in annexes A1 and A2.

2. Specification of the intended use in accordance with the applicable European Assessment Document.

2.1 Intended use

This ETA covers fasteners to be used in compacted, reinforced or unreinforced, normal weight, cracked or uncracked concrete without fibers with strength classes in the range of C20/25 to C50/60 all in accordance with EN 206, for static or quasi-static or under seismic actions (categories C1 and C2) and with requirements related to fire exposure, loaded in tension, shear or combined tension and shear.

The performances given in section 3 are only valid if the anchor is used in compliance with the specifications and conditions given in annexes B1 and B2.

2.2 Relevant general conditions for the use of the product

The assessment methods included or referred to in this EAD have been written based on the manufacturer's request to take into account a working life of the fastener for the intended use of 50 years when installed in the works (provided that the fastener is subject to appropriate installation). These provisions are based upon the current state of the art and the available knowledge and experience.

When assessing the product, the intended use as foreseen by the manufacturer shall be taken into account. The real working life may be, in normal use conditions, considerably longer without major degradation affecting the basic requirements for works.

The indications given as to the working life of the construction product cannot be interpreted as a guarantee neither given by the product manufacturer or its representative nor by EOTA when drafting the EAD nor by the Technical Assessment Body issuing an ETA based on this EAD, but are regarded only as a mean for expressing the expected economically reasonable working life of the product.

This ETA covers fasteners for installation in pre-drilled holes in compacted reinforced or unreinforced normal weight concrete without fibers considering annexes B and C.

3. Performance of the product and references to the methods used for its assessment

The identification tests and the assessment for the intended use of this product according to the Basic Work Requirements (BWR) were carried out in compliance with EAD 330232-01-0601. The



characteristics of each system shall correspond to the respective values laid down in following tables of this ETA, checked by IETcc.

Methods of verification and of assessing and judging are listed afterwards.

3.1 Mechanical resistance and stability (BWR 1)

Essential characteristic	Relevant clause in EAD	Performance	Annex
Resistance to steel failure	2.2.1	$N_{Rk,s}$ [kN]	C5, C6
Resistance to pull-out failure	2.2.2	$N_{Rk,p}$ [kN] ψ_c [-]	C5, C6
Resistance to concrete cone failure	2.2.3	$k_{cr,N}$, $k_{ucr,N}$ [-] h_{ef} , $c_{cr,N}$ [mm]	C5, C6
Robustness	2.2.4	γ_{inst} [-]	C5, C6
Minimum edge distance and spacing	2.2.5	c_{min} , s_{min} , h_{min} [mm]	C1 to C3
Edge distance to prevent splitting under load	2.2.6	$N^0_{Rk,sp}$ [kN], $c_{cr,sp}$ [mm]	C5, C6
Resistance to steel failure under shear load	2.2.7	$V^0_{Rk,s}$ [kN], $M^0_{Rk,s}$ [Nm], k_7 [-]	C7, C8
Resistance to pry-out failure	2.2.8	k_8 [-]	C7, C8
Displacement under static and quasi-static loading	2.2.10	δ_{N0} , $\delta_{N\infty}$, δ_{V0} , $\delta_{V\infty}$ [mm]	C9, C10
Resistance to seismic tension loads; displacements	2.2.11 2.2.12	$N_{Rk,s,C1}$, $N_{Rk,p,C1}$ [kN] $N_{Rk,s,C2}$, $N_{Rk,p,C2}$ [kN], $\delta_{N,C2}$ [mm]	C11 to C13
Resistance to seismic shear loads; displacements	2.2.13 2.2.14	$V_{Rk,s,C1}$ [kN], $V_{Rk,s,C2}$ [kN], $\delta_{V,C2}$ [mm]	C11 to C13
Factor for annular gap	2.2.15	α_{gap} [-]	C11 to C13

3.2 Safety in case of fire (BWR 2)

Essential characteristic	Relevant clause in EAD	Performance	Annex
Reaction to fire	2.2.16	Anchorage satisfy requirements for class A1 according to EN 13501-1	--
Fire resistance to steel failure, tension load	2.2.17	$N^0_{Rk,s,fi}$ [kN]	C14 to C27
Fire resistance to pull out failure, tension load	2.2.18	$N^0_{Rk,p,fi}$ [kN]	C14 to C27
Fire resistance to steel failure, shear load	2.2.19	$V^0_{Rk,s,fi}$ [kN] $M^0_{Rk,s,fi}$ [Nm]	C14 to C27



3.3 Durability

Essential characteristic	Relevant clause in EAD	Performance	Annex
Durability:	2.2.20	Coated in zinc plated Coated in zinc nickel Coated in zinc flake Coated mechanical galvanized Coated in Atlantis Stainless steel	A2

4. Assessment and Verification of Constancy of Performance (hereinafter AVCP) system applied, with reference to its legal base

The applicable European legal act for the system of Assessment and Verification of Constancy of Performance (see annex V to Regulation (EU) No 305/2011) is 96/582/EC.

The system to be applied is 1.

5. Technical details necessary for the implementation of the AVCP system, as provided for in the applicable European Assessment Document.

Technical details necessary for the implementation of the AVCP system are laid down in the quality plan which is deposited at IETcc⁽¹⁾.







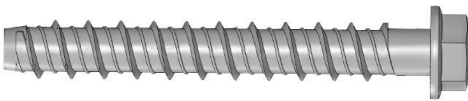

Prepared by: PhD Julián Rivera (Innovative Products Assessment Unit, IETcc-CSIC)

Issued in Madrid on 18th of September 2025

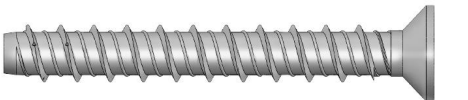
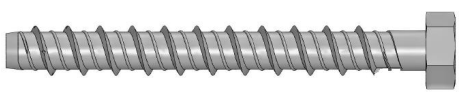
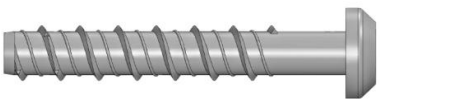
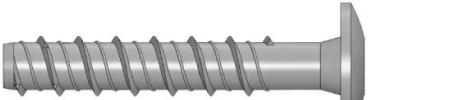
Director
on behalf of Instituto de Ciencias de la Construcción Eduardo Torroja (IETcc – CSIC)

⁽¹⁾ The Quality Plan is a confidential part of the ETA and only handed over to the notified certification body involved in the assessment and verification of constancy of performance.

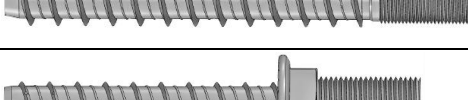
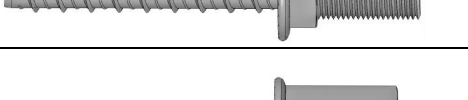

Product types			
Picture	Material / coating	Head styles / Sizes	
	Carbon steel: -H: Atlantis -F: Zinc plated -N: Zinc flake -K: Zinc nickel -G: Mechanical galvanized	-E, -K: Hexagonal head with flange. Sizes: 6, 8, 10, 12, 14, 16 and 18	
		-J: Hexagonal head with flange. Six lobe recess. Size: 6	
		-A: Countersunk head, Six lobe recess Sizes: 6, 8 10 and 12	
		-N: Hexagonal head. Sizes: 6, 8, 10, 12, 14, 16 and 18	
		-P: Pan head. Six lobe recess Sizes: 6 and 8	
		-T: Truss head. Six lobe recess. Size: 6	
		-D: Dome head: Sizes 6, 8, 10, 12	
		Stainless steel: -X: A4 stainless steel	-W: Stud head with DIN 934 class 6 nut and DIN 125 washer Sizes: 6 M8, 8 M10, 10 M12, 12 M14, 14 M16, 16 M18 and 18 M20
		-S: Stud head Sizes: 6 M8, 8 M10, 10 M12, 12 M14, 14 M16, 16 M18 and 18 M20	
		-M: Male thread Size: 6, external thread M8, M10; 8 external thread M10, M12	
	-F: Rod hanger Size 6: internal thread M10; combi thread M8/M10 Size 8: internal thread M10; M12		
			
THE, TXE screw anchor		Annex A1	
Product description			
Screw types			



Installed condition

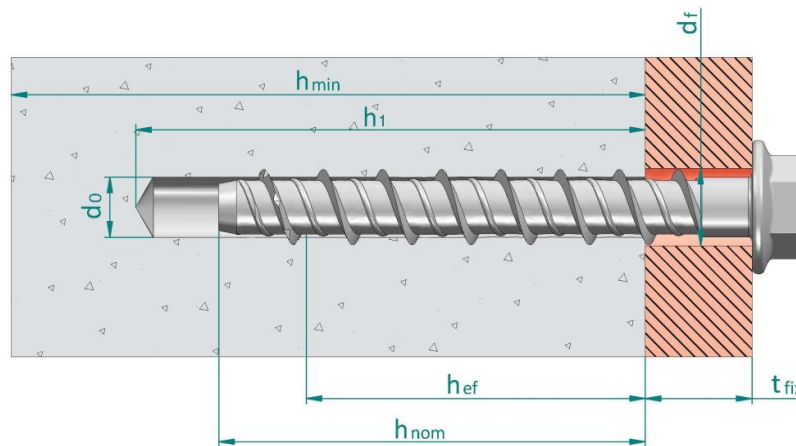

- d_0 : Nominal diameter of drill bit
- d_f : Fixture clearance hole diameter
- h_{ef} : Effective anchorage depth
- h_1 : Depth of drilled hole
- h_{nom} : Overall fastener embedment depth in the concrete
- h_{min} : Minimum thickness of concrete member
- t_{fix} : Fixture thickness

Identification on head of fastener: company logo + size x length

The tip of the thread may be coloured.

For heads where no enough space is available, the length of the mark can be replaced by the following letter codes.

Letter on head	Length [mm]
A	35 ÷ 50
B	51 ÷ 62
C	63 ÷ 75
D	76 ÷ 88
E	89 ÷ 101
F	102 ÷ 113
G	114 ÷ 126
H	127 ÷ 139
I	140 ÷ 153

Table A1: Materials

Item	Designation	Material for screw anchor carbon steel versions TH / TF / TN / TK / TG	Material for screw anchor stainless steel version TX
1	Fastener body	Carbon steel, galvanized $\geq 5 \mu\text{m}$ ISO 4042 Zn5 Carbon steel, zinc nickel $\geq 8 \mu\text{m}$ ISO 4042, ZnNi8/An/T2 Carbon steel, zinc flake $\geq 6 \mu\text{m}$ ISO 10683 Carbon steel, mechanical galvanizing $\geq 40 \mu\text{m}$ EN ISO 12683 Zn 40 M(Fe) Carbon steel, Atlantis coating	Shaft and head: stainless steel grade A4 ISO 3506-1 Tip: hardened carbon steel

THE, TXE screw anchor

Product description

Installed condition and materials

Annex A2



Specifications of intended use																
Size	6			8		10			12		14		16		18	
h_{nom}	35	40	55	50	65	55	75	85	75	105	75	115	80	120	90	140
Carbon steel versions TH / TF / TN / TK / TG																
Static or quasi static loads	✓	✓	✓	✓	✓	✓	✓	✓	✓	✓	✓	✓	✓	✓	✓	✓
Seismic category C1		✓	✓	✓	✓	✓		✓	✓	✓		✓	✓	✓		✓
Seismic category C2				✓	✓			✓		✓		✓		✓		✓
Fire exposure up to 120 minutes	✓	✓	✓	✓	✓	✓	✓	✓	✓	✓	✓	✓	✓	✓	✓	✓
Stainless steel versions TX																
Static or quasi static loads	✓	✓	✓	✓	✓	✓		✓	✓	✓						
Seismic category C1		✓	✓	✓	✓	✓		✓	✓	✓						
Seismic category C2																
Fire exposure up to 120 minutes	✓	✓	✓	✓	✓	✓		✓	✓	✓						
Base materials:																
<ul style="list-style-type: none"> Reinforced or unreinforced normal weight concrete without fibres according to EN 206:2013 + A2:2021. Strength classes C20/25 to C50/60 according to EN 206:2013 + A2:2021. Cracked or uncracked concrete. 																
Use conditions:																
<ul style="list-style-type: none"> Base material temperature range: -40 °C to + 80 °C. Carbon steel versions TH / TF / TN / TK / TG: environmental conditions: anchorages subjected to dry internal conditions. Stainless steel version TX: environmental conditions: anchorages subjected to dry internal conditions, to external atmospheric exposure (including industrial and marine environment) or to permanent internal damp conditions if no particular aggressive conditions exist. Such particular aggressive conditions are e.g., permanent, alternating immersion in seawater or the splash zone of seawater, chloride atmosphere of indoor swimming pools or atmosphere with extreme chemical pollution (e.g., in desulphurization plants or road tunnels where de-icing materials are used). Atmospheres under Corrosion Resistance Class CRC III according to EN 1993-1-4:2006+A1:2015 annex A. Male and female version: the metric thread shall be equal or bigger than the net section of the concrete thread 																
THE, TXE screw anchor															Annex B1	
Intended use																
Specifications																



<p>Design:</p> <ul style="list-style-type: none"> • Anchorages are designed under the responsibility of an engineer experienced in anchorages and concrete work. • Verifiable calculation rules and drawings are prepared taking into account of the loads to be anchored. The position of the fastener is indicated on the design drawings (e.g., position of the fastener relative to reinforcement or to supports, etc.). • Anchorages under static or quasi static actions are designed for design method A in accordance with EN 1992-4:2018. • Anchorages under seismic actions are designed in accordance with EN 1992-4:2018. Anchorages shall be positioned outside of critical regions (e.g., plastic hinges) of the concrete structure. Fastening in stand-off installation or with grout layer are not allowed. • Anchorages under fire exposure are designed in accordance with EN 1992-4:2018. It must be ensured that local spalling of the concrete cover does not occur. <p>Installation:</p> <ul style="list-style-type: none"> • Hole drilling by rotary plus hammer mode: all sizes and embedment depths. • Fastener installation carried out by appropriately qualified personal and under the supervision of the person responsible for technical matters of the site. • In case of aborted hole: new drilling at a minimum distance away of twice the depth of aborted hole or smaller distance if the aborted hole is filled with high strength mortar and if under shear or oblique tension load it is not the direction of the load application. • After installation further turning of the anchor must not be possible. • The head of the fastener must be supported on the fixture and is not damaged. • Anchors can be installed only once. 	
THE, TXE screw anchor	Annex B2
Intended use	
Specifications	



Table C1: Installation parameters carbon steel versions TH / TF / TN / TK / TG

Installation parameters carbon steel versions TH / TF / TN / TK / TG			Performances								
			6		8		10				
h_{nom}	Nominal embedment depth:	[mm]	35	40	55	50	65	55	75	85	
h_{ef}	Effective anchorage depth:	[mm]	26,0	30,0	43,0	37,5	50,5	41,5	58,5	67,0	
d_0	Nominal diameter of drill bit:	[mm]	6		8		10				
d_f	Clearance hole diameter \leq	[mm]	7,5 ÷ 9		10,5 ÷ 12		12,5 ÷ 14				
$T_{inst,max}$	Installation torque \leq	[Nm]	10		20		30				
h_1	Depth of drilled hole \geq	[mm]	45	50	65	60	75	65	85	95	
$h_{1,bit}$	Depth of drilled hole for drill bit cleaning \geq	[mm]	57	62	77	76	91	85	105	115	
h_{min}	Minimum thickness of concrete member:	[mm]	100	100	100	100	100	100	120	135	
L_{min}	Minimum total length of fasten.	[mm]	35	40	55	50	65	55	75	85	
t_{fix}	Thickness of fixture ¹⁾ :	[mm]	L-35	L-40	L-55	L-50	L-65	L-55	L-75	L-85	
t_{rx}	Thickness of fixture, stud version ¹⁾ :	[mm]	L-44	L-49	L-64	L-59	L-74	L-65	L-85	L-95	
SW	Socket size	Hexagonal type E,N	[mm]	10		13		15			
		Hexagonal type K:	[mm]	10		13		17			
		Hexagonal type J:	[mm]	13		--		--			
		Dome:	[mm]	10		13		16			
		Male:	[mm]	13		17		--			
		Rod hanger:	[mm]	13		13 / 17 ²⁾		--			
TX	Six lobe recess	Countersunk:	[-]	30		45		50			
		Pan:	[-]	40		45		--			
		Truss:	[-]	30		--		--			
d_k	Diam. of countersunk head:	[mm]	12,4		18		21				
s_{min}	Minimum allowable spacing:	[mm]	35		35		50				
c_{min}	Minimum allowable distance:	[mm]	35		35		40				
Setting tool:			Bosch GDS 18E, 500 W. $T_{impact,max}$ 250 Nm, or equivalent			Makita TW0350, 400 W, $T_{impact,max}$ 350 Nm, or equiv.		Bosch GDS 24, 800 W. $T_{impact,max}$ 600 Nm, or equivalent			

¹⁾ L = total fastener length
²⁾ Socket 13 for M10; socket 17 for M12

THE screw anchor	Annex C1
Performances	
Installation parameters	



Table C2: Installation parameters carbon steel versions TH / TF / TN / TK / TG (cont)										
Installation parameters carbon steel versions TH / TF / TN / TK / TG				Performances						
				12		14		16		18
h_{nom}	Nominal embedment depth:	[mm]	75	105	75	115	80	120	90	140
h_{er}	Effective anchorage depth:	[mm]	58,0	83,5	58,0	92,0	58,0	92,0	69,5	112,0
d_0	Nominal diameter of drill bit:	[mm]	12		14		16		18	
d_f	Clearance hole diameter \leq	[mm]	14,8 \div 16		16,9 \div 18		18,9 \div 20		20,9 \div 22	
$T_{inst,max}$	Installation torque \leq	[Nm]	50		70		80		90	
h_1	Depth of drilled hole \geq	[mm]	90	120	90	130	100	140	110	160
$h_{1,bit}$	Depth of drilled hole for drill bit cleaning \geq	[mm]	114	144	118	158	132	172	146	196
h_{min}	Minimum thickness of concrete member:	[mm]	120	170	120	185	115	185	140	225
L_{min}	Minimum total length of fasten.	[mm]	75	105	75	115	80	120	90	140
t_{fix}	Thickness of fixture ¹⁾ :	[mm]	L-75	L-105	L-75	L-115	L-80	L-120	L-90	L-140
t_{fix}	Thickness of fixture, stud version ¹⁾ :	[mm]	L-86	L-116	L-87	L-127	L-94	L-134	L-105	L-155
SW	Socket size:	Hexagonal type E,N	[mm]	18	21	24	24	24	24	24
		Hexagonal type K:	[mm]	19	21	24	24	26	26	
		Dome:	[mm]	18	--	--	--	--	--	
		Rod hanger:	[mm]	M12: 19	--	--	--	--	--	
		Stud:	[mm]	10	12	13	14	14	14	
TX	Six lobe recess countersunk	[-]	55	--	--	--	--	--	--	--
d_k	Diam. of countersunk head:	[mm]	24	--	--	--	--	--	--	--
s_{min}	Minimum allowable spacing:	[mm]	75	80	80	80	80	80	90	90
c_{min}	Minimum allowable edge distance:	[mm]	45	50	50	50	50	50	55	55
Setting tool:			Bosch GDS 24, 800 W. $T_{impact,max}$ 600 Nm, or equivalent							
¹⁾ L = total fastener length										
THE screw anchor									Annex C2	
Performances										
Installation parameters										



Table C3: Installation parameters stainless steel version TX											
Installation parameters stainless steel version TX			Performances								
			6			8		10		12	
h_{nom}	Nominal embedment depth:	[mm]	35	40	55	50	65	55	85	75	105
h_{ef}	Effective anchorage depth:	[mm]	26,0	30,0	43,0	37,5	50,5	41,5	67,0	58,0	83,5
d_o	Nominal diameter of drill bit:	[mm]	6			8		10		12	
d_f	Clearance hole diameter \leq	[mm]	9			12		14		16	
$T_{inst,max}$	Installation torque \leq	[Nm]	10			20		30		50	
h_1	Depth of drilled hole \geq	[mm]	45	50	65	60	75	65	95	90	120
$h_{1,bit}$	Depth of drilled hole for drill bit cleaning \geq	[mm]	57	62	77	76	91	85	115	114	144
h_{min}	Minimum thickness of concrete member:	[mm]	80	80	80	80	80	80	100	120	160
L_{min}	Minimum total length of the fastener:	[mm]	35	40	55	50	65	55	85	75	105
t_{fix}	Thickness of fixture ¹⁾ :	[mm]	L-35	L-40	L-55	L-50	L-65	L-55	L-85	L-75	L-105
t_{fix}	Thickness of fixture, stud version ¹⁾ :	[mm]	L-44	L-49	L-64	L-59	L-74	L-65	L-95	L-86	L-116
SW	Socket size	Hexagonal type: E,N:	10			13		15		18	
		Hexagonal type: K:	10			13		17		19	
		Hexagonal type: J:	13			--		--		--	
		Dome:	10			13		16		18	
		Male:	13			17		--		--	
		Rod hanger:	13			13 / 17 ²⁾		--		--	
		Stud:	5			7		8		10	
TX	Six lobe recess	Countersunk:	30			45		50		55	
		Pan:	40			45		--		--	
		Truss:	30			--		--		--	
d_k	Diameter of countersunk head:	[mm]	12,4			18		21		24	
s_{min}	Minimum allowable spacing:	[mm]	35			35		50		75	
c_{min}	Minimum allowable distance:	[mm]	35			35		40		45	
Setting tool			Bosch GDS 18E, 500 W. $T_{impact,max}$ 250 Nm, or equivalent				Bosch GDS 24, 800 W. $T_{impact,max}$ 600 Nm, or equivalent				
¹⁾ L = total fastener length ²⁾ Socket 13 for M10; socket 17 for M12											
TXE screw anchor										Annex C3	
Performances											
Installation parameters											





Installation procedure	
	<p>1. DRILL</p> <p>Drill a hole into the base material of the correct diameter and depth using a carbide drill bit in rotary plus hammer mode.</p>
	<p>2.a) BLOW AND CLEAN</p> <p>Remove dust and debris from hole using a hand pump, compressed air or a vacuum to remove loose particles left from drilling.</p>
	<p>2 b) CLEAN WITH DRILL BIT</p> <p>Alternatively to 2.a):</p> <ul style="list-style-type: none"> • Upward installation direction: no cleaning is needed. • Downward or horizontal installation direction: no cleaning is needed if drilling depth is $h_{1,bit}$, and after the drilling process the drill bit is moved in and out of the hole for 3 times with both rotary and hammer modes of the drilling machine activated.
	<p>3. INSTALL</p> <p>Select a powered impact wrench or a torque wrench that does not exceed the maximum torque $T_{impact,max}$ or $T_{inst,max}$ respectively. Attach an appropriately sized hex socket or six lob bit to the wrench. Mount the screw anchor head in the socket / bit.</p>
	<p>4. APPLY TORQUE</p> <p>Drive the anchor with an impact driver or a torque wrench through the fixture and into the hole until the anchor head comes in contact with the fixture. The anchor must be snug after installation. Do not spin the socket off the anchor to disengage.</p>
THE, TXE screw anchor	
Performances	Annex C4
Installation procedure	



Table C4: Characteristic values under static or quasi-static tension loads of design method A according to EN1992-4, carbon steel versions TH / TF / TN / TK / TG

Characteristic values under static or quasi-static tension loads according to design method A, carbon steel versions TH / TF / TN / TK / TG			Performances								
			6		8		10				
h_{nom}	Nominal embedment depth:	[mm]	35	40	55	50	65	55	75	85	
Resistance to steel failure											
$N_{Rk,s}$	Characteristic resistance:	[kN]	25,12			39,14		54,81			
γ_{Ms}	Partial safety factor ¹⁾ :	[-]	1,4								
Resistance to pull out failure											
$N_{Rk,p}$	Characteristic resistance in C20/25 uncracked concrete:	[kN]	5	$\geq N_{Rk,c}^{0,2)}$							
$N_{Rk,p}$	Characteristic resistance in C20/25 cracked concrete:	[kN]	$\geq N_{Rk,c}^{0,2)}$								
ψ_c	Increasing factor for concrete	C30/37	[-]	1,16	1,12	1,22	1,21	1,22	1,22	1,17	1,22
		C40/50	[-]	1,28	1,22	1,41	1,39	1,41	1,41	1,30	1,41
		C50/60	[-]	1,39	1,29	1,58	1,54	1,58	1,58	1,42	1,58
Resistance to concrete cone and splitting failure											
h_{ef}	Effective anchorage depth:	[mm]	26,0	30,0	43,0	37,5	50,5	41,5	58,5	67,0	
$k_{ucr,N}$	Factor for uncracked concrete:	[-]	11,0								
$k_{cr,N}$	Factor for cracked concrete:	[-]	7,7								
γ_{inst}	Robustness:	[-]	1,2	1,2	1,0	1,2	1,0	1,0	1,0	1,0	
$s_{cr,N}$	Concrete Spacing:	[mm]	3 x h_{ef}								
$s_{cr,N}$	cone failure Edge distance:	[mm]	1,5 x h_{ef}								
$N_{Rk,sp}^0$	Charact. splitting resistance:	[kN]	$\min(N_{Rk,p}; N_{Rk,c}^0)$								
$s_{cr,sp}$	Spitting Spacing:	[mm]	90	90	170	130	200	140	190	210	
$s_{cr,sp}$	failure Edge distance:	[mm]	45	45	85	65	100	70	95	105	

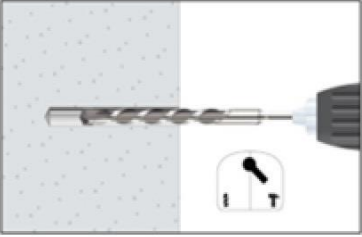
¹⁾ In absence of other national regulations; ²⁾ Pull out failure is not decisive. $N_{Rk,c}^0$ calculated according to EN 1992-4

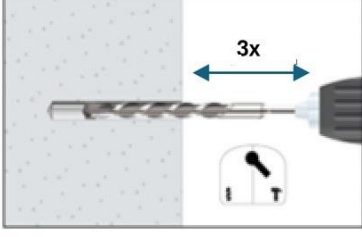
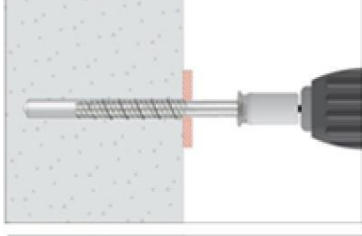
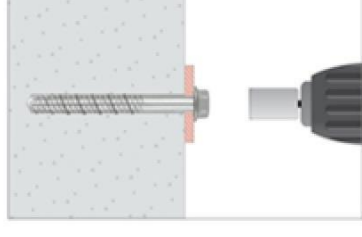
Characteristic values under static or quasi-static tension loads according to design method A, carbon steel versions TH / TF / TN / TK / TG			Performances								
			12		14		16		18		
h_{nom}	Nominal embedment depth:	[mm]	75	105	75	115	80	120	90	140	
Resistance to steel failure											
$N_{Rk,s}$	Characteristic resistance:	[kN]	74,48		105,45		124,41		161,56		
γ_{Ms}	Partial safety factor ¹⁾ :	[-]	1,4								
Resistance to pull out failure											
$N_{Rk,p}$	Characteristic resistance in C20/25 uncracked concrete:	[kN]	$\geq N_{Rk,c}^{0,2)}$								
$N_{Rk,p}$	Characteristic resistance in C20/25 cracked concrete:	[kN]	$\geq N_{Rk,c}^{0,2)}$								
ψ_c	Increasing factor for concrete	C30/37	[-]	1,16	1,22	1,21	1,20	1,12	1,16	1,22	1,17
		C40/50	[-]	1,29	1,41	1,39	1,37	1,21	1,28	1,40	1,32
		C50/60	[-]	1,40	1,58	1,55	1,51	1,29	1,39	1,57	1,42
Resistance to concrete cone and splitting failure											
h_{ef}	Effective anchorage depth:	[mm]	58,0	83,5	58,0	92,0	58,0	92,0	69,5	112,0	
$k_{ucr,N}$	Factor for uncracked concrete:	[-]	11,0								
$k_{cr,N}$	Factor for cracked concrete:	[-]	7,7								
γ_{inst}	Robustness:	[-]	1,0								
$s_{cr,N}$	Concrete Spacing:	[mm]	3 x h_{ef}								
$s_{cr,N}$	cone failure Edge distance:	[mm]	1,5 x h_{ef}								
$N_{Rk,sp}^0$	Charact. splitting resistance:	[kN]	$\min(N_{Rk,p}; N_{Rk,c}^0)$								
$s_{cr,sp}$	Spitting Spacing:	[mm]	190	220	190	230	180	280	230	350	
$s_{cr,sp}$	failure Edge distance:	[mm]	95	110	95	115	90	140	115	175	

¹⁾ In absence of other national regulations; ²⁾ Pull out failure is not decisive. $N_{Rk,c}^0$ calculated according to EN 1992-4

THE screw anchor	Annex C5
Performances	
Characteristic values under static or quasi-static tension loads	



Table C5: Characteristic values under static or quasi-static tension loads of design method A according to EN1992-4, stainless steel version TX											
Characteristic values under static or quasi-static tension loads according to design method A, stainless steel version TX			Performances								
			6			8		10		12	
h_{nom}	Nominal embedment depth:	[mm]	35	40	55	50	65	55	85	75	105
Resistance to steel failure											
$N_{Rk,s}$	Characteristic resistance:	[kN]	17,58			29,30		48,13		69,67	
γ_{Ms}	Partial safety factor ¹⁾ :	[-]	1,5								
Resistance to pull out failure											
$N_{Rk,p}$	Characteristic resistance in C20/25 uncracked concrete:	[kN]	5,5	$\geq N_{Rk,c}^{(2)}$	12,0	10,0	$\geq N_{Rk,c}^{(2)}$	$\geq N_{Rk,c}^{(2)}$	$\geq N_{Rk,c}^{(2)}$	$\geq N_{Rk,c}^{(2)}$	$\geq N_{Rk,c}^{(2)}$
$N_{Rk,p}$	Characteristic resistance in C20/25 cracked concrete:	[kN]	1,0	2,5	7,5	5,0	$\geq N_{Rk,c}^{(2)}$	$\geq N_{Rk,c}^{(2)}$	$\geq N_{Rk,c}^{(2)}$	14,0	$\geq N_{Rk,c}^{(2)}$
Ψ_c	Increasing factor for concrete	C30/37 [-]	1,12	1,10	1,06	1,10	1,08	1,08	1,08	1,10	1,08
		C40/50 [-]	1,21	1,18	1,10	1,17	1,15	1,14	1,14	1,18	1,15
		C50/60 [-]	1,29	1,24	1,14	1,23	1,19	1,19	1,18	1,25	1,19
Resistance to concrete cone and splitting failure											
h_{ef}	Effective anchorage depth:	[mm]	26,0	30,0	43,0	37,5	50,5	41,5	67,0	58,0	83,5
$k_{ucr,N}$	Factor for uncracked concrete:	[-]	11,0								
$k_{cr,N}$	Factor for cracked concrete:	[-]	7,7								
γ_{inst}	Robustness:	[-]	1,2	1,2	1,2	1,2	1,2	1,2	1,2	1,2	1,0
$s_{cr,N}$	Concrete cone Spacing:	[mm]	3 x h_{ef}								
$c_{cr,N}$	Edge failure distance	[mm]	1,5 x h_{ef}								
$N_{Rk,sp}^0$	Characteristic splitting resistance:	[kN]	min ($N_{Rk,p}$; $N_{Rk,c}^0$)								
$s_{cr,sp}$	Spitting Spacing:	[mm]	90	110	190	130	220	140	230	190	240
$c_{cr,sp}$	Edge failure distance	[mm]	45	55	95	65	110	70	115	95	120
¹⁾ In absence of other national regulations ²⁾ Pull out failure is not decisive. $N_{Rk,c}^0$ calculated according to EN 1992-4											
TXE screw anchor										Annex C6	
Performances											
Characteristic values under static or quasi-static tension loads											



Table C6: Characteristic values under static or quasi-static shear loads of design method A according to EN 1992-4, carbon steel versions TH / TF / TN / TK / TG

Characteristic values under static or quasi-static shear loads according to design method A, carbon steel versions TH / TF / TN / TK / TG		Performances								
		6			8			10		
h_{nom}	Nominal embedment depth: [mm]	35	40	55	50	65	55	75	85	
Resistance to steel failure under shear loads										
$V_{Rk,s}^0$	Characteristic resistance: [kN]	12,53			19,57			27,40		
k_7	Ductility factor ²⁾ : [-]	0,78	0,80	0,78	0,80			0,80		
$M_{Rk,s}^0$	Characteristic bending moment: [Nm]	21,6			44,6			78,3		
γ_{Ms}	Partial safety factor ¹⁾ : [-]	1,5								
Resistance to pry-out failure										
k_8	Pry-out factor: [-]	2,05	1,44	1,15	1,80	1,27	1,95	1,32	2,00	
γ_{inst}	Robustness: [-]	1,0								
Resistance to concrete edge failure										
l_f	Effective length of fastener under shear loads: [mm]	26,0	30,0	43,0	37,5	50,5	41,5	58,5	67,0	
d_{nom}	Outside fastener diameter: [mm]	6			8			10		
γ_{inst}	Robustness: [-]	1,0								

- 1) In absence of other national regulations
- 2) The diameter of the clearance hole does not meet the values given in EN 1992-4 Table 6.1. However, the group resistance under shear loading has been verified in the assessment through testing and accounted for in the factor k_7

Characteristic values under static or quasi-static shear loads according to design method A, carbon steel versions TH / TF / TN / TK / TG		Performances									
		12			14			16			18
h_{nom}	Nominal embedment depth: [mm]	75	105	75	115	80	120	90	140		
Resistance to steel failure under shear loads											
$V_{Rk,s}^0$	Characteristic resistance: [kN]	37,24			52,72			57,97			80,78
k_7	Ductility factor ²⁾ : [-]	1,00									
$M_{Rk,s}^0$	Characteristic bending moment: [Nm]	126,5			218,3			279,75			421,2
γ_{Ms}	Partial safety factor ¹⁾ : [-]	1,5									
Resistance to pry-out failure											
k_8	Pry-out factor: [-]	2,33	2,00	2,55	2,00	2,14	2,00	2,66	2,00		
γ_{inst}	Robustness: [-]	1,0									
Resistance to concrete edge failure											
l_f	Effective length of fastener under shear loads: [mm]	58,0	83,5	58,0	92,0	58,0	92,0	69,5	112,0		
d_{nom}	Outside fastener diameter: [mm]	12			14			16			18
γ_{inst}	Robustness: [-]	1,0									

- 1) In absence of other national regulations
- 2) The diameter of the clearance hole does not meet the values given in EN 1992-4 Table 6.1. However, the group resistance under shear loading has been verified in the assessment through testing and accounted for in the factor k_7

THE screw anchor

Performances

Characteristic values under static or quasi-static shear loads

Annex C7



Table C7: Characteristic values under static or quasi-static shear loads of design method A according to EN 1992-4, stainless steel version TX

Characteristic values under static or quasi-static shear loads according to design method A, stainless steel version TX		Performances									
		6			8		10		12		
h_{nom}	Nominal embedment depth: [mm]	35	40	55	50	65	55	85	75	105	
Resistance to steel failure under shear loads											
$V_{Rk,s}^0$	Characteristic resistance: [kN]	8,79			14,65		24,06		34,84		
k_7	Ductility factor ²⁾ : [-]	1,00									
$M_{Rk,s}^0$	Characteristic bending moment: [Nm]	14,52			31,17		65,68		146,01		
γ_{Ms}	Partial safety factor ¹⁾ : [-]	1,25									
Resistance to pry-out failure											
k_8	Pry-out factor: [mm]	1,87	1,66	1,05	1,71	1,39	1,83	2,00	2,19	2,00	
γ_{inst}	Robustness: [-]	1,0									
Resistance to concrete edge failure											
l_f	Effective length of fastener under shear loads: [mm]	26,0	30,0	43,0	37,5	50,5	41,5	67,0	58,0	83,5	
d_{nom}	Outside fastener diameter: [mm]	6			8		10		12		
γ_{inst}	Robustness: [-]	1,0									

¹⁾ In absence of other national regulations

²⁾ The diameter of the clearance hole does not meet the values given in EN 1992-4 Table 6.1. However, the group resistance under shear loading has been verified in the assessment through testing and accounted for in the factor k_7

TXE screw anchor	Annex C8
Performances	
Characteristic values under static or quasi-static shear loads	



Table C8: Displacements under service loads carbon steel versions TH / TF / TN / TK / TG

Displacements under service loads, carbon steel versions TH / TF / TN / TK / TG		Performances								
		6			8			10		
h_{nom}	Nominal embedment depth: [mm]	35	40	55	50	65	55	75	85	
Displacements under tension loads in uncracked concrete										
N	Service tension load: [kN]	1,98	3,85	6,61	4,48	8,41	6,26	10,48	12,85	
δ_{N0}	Short term displacement: [mm]	0,03	0,05	0,05	0,04	0,05	0,06	0,09	0,10	
$\delta_{N\infty}$	Long term displacement: [mm]	0,25	0,30	0,30	0,26	0,35	0,30	0,42	0,65	
Displacements under tension loads in cracked concrete										
N	Service tension load: [kN]	1,81	2,69	4,62	3,14	5,88	4,38	7,34	8,99	
δ_{N0}	Short term displacement: [mm]	0,08	0,09	0,10	0,09	0,20	0,11	0,35	0,44	
$\delta_{N\infty}$	Long term displacement: [mm]	0,99	0,99	1,60	1,08	1,92	1,13	2,00	1,91	
Displacements under shear loads in uncracked concrete										
V	Service shear load: [kN]	5,97	5,54	5,97	9,32	9,32	12,21	13,05	13,05	
δ_{V0}	Short term displacement: [mm]	1,50	1,61	1,70	1,03	1,03	1,11	1,21	1,24	
$\delta_{V\infty}$	Long term displacement: [mm]	2,25	2,41	2,55	1,54	1,54	1,66	1,81	1,86	
Displacements under shear loads in cracked concrete										
V	Service shear load: [kN]	4,46	3,88	5,32	6,78	7,47	8,55	9,68	13,05	
δ_{V0}	Short term displacement: [mm]	0,95	0,96	1,45	0,66	0,70	0,74	1,03	1,09	
$\delta_{V\infty}$	Long term displacement: [mm]	1,42	1,44	2,17	0,99	1,05	1,11	1,54	1,63	

Displacements under service loads, carbon steel versions TH / TF / TN / TK / TG		Performances							
		12		14		16		18	
h_{nom}	Nominal embedment depth: [mm]	75	105	75	115	80	120	90	140
Displacements under tension loads in uncracked concrete									
N	Service tension load: [kN]	10,35	17,87	10,35	20,67	10,35	20,67	13,57	27,77
δ_{N0}	Short term displacement: [mm]	0,10	0,11	0,12	0,15	0,12	0,20	0,17	0,23
$\delta_{N\infty}$	Long term displacement: [mm]	0,40	0,68	0,46	0,70	0,60	0,74	0,50	0,71
Displacements under tension loads in cracked concrete									
N	Service tension load: [kN]	7,24	12,51	7,24	14,47	7,24	14,47	9,50	19,44
δ_{N0}	Short term displacement: [mm]	0,24	0,46	0,34	0,51	0,39	0,59	0,41	0,55
$\delta_{N\infty}$	Long term displacement: [mm]	1,32	1,78	1,40	1,80	1,41	1,85	1,56	2,08
Displacements under shear loads in uncracked concrete									
V	Service shear load: [kN]	17,73	17,73	25,10	25,10	22,14	33,12	36,10	38,47
δ_{V0}	Short term displacement: [mm]	1,65	1,65	1,87	1,87	1,04	1,61	1,96	2,03
$\delta_{V\infty}$	Long term displacement: [mm]	2,48	2,48	2,81	2,81	1,56	2,42	2,94	3,05
Displacements under shear loads in cracked concrete									
V	Service shear load: [kN]	16,88	17,73	18,47	25,10	15,50	28,94	25,27	38,47
δ_{V0}	Short term displacement: [mm]	1,30	1,34	1,40	1,70	0,86	1,56	1,34	1,80
$\delta_{V\infty}$	Long term displacement: [mm]	1,95	2,01	2,10	2,55	1,29	2,34	2,01	2,70

THE screw anchor

Performances

Displacements under static or quasi-static tension and shear loads

Annex C9



Table C9: Displacements under service loads stainless steel version TX

Displacements under service loads, stainless steel version TX			Performances								
			6			8		10		12	
h_{nom}	Nominal embedment depth:	[mm]	35	40	55	50	65	55	85	75	105
Displacements under tension loads in uncracked concrete											
N	Service tension load:	[kN]	2,34	3,21	4,93	4,25	7,00	5,22	10,71	8,62	17,88
δ_{N0}	Short term displacement:	[mm]	0,04	0,04	0,06	0,09	0,10	0,10	0,12	0,12	0,18
$\delta_{N\infty}$	Long term displacement:	[mm]	0,28	0,30	0,30	0,35	0,40	0,40	0,45	0,45	0,50
Displacements under tension loads in cracked concrete											
N	Service tension load:	[kN]	0,56	1,07	3,20	2,06	4,90	3,65	7,50	5,63	12,51
δ_{N0}	Short term displacement:	[mm]	0,06	0,07	0,14	0,13	0,15	0,17	0,18	0,20	0,23
$\delta_{N\infty}$	Long term displacement:	[mm]	0,60	0,53	0,86	0,55	1,11	0,57	0,92	0,67	1,06
Displacements under shear loads in uncracked concrete											
V	Service shear load:	[kN]	4,36	5,06	5,06	7,70	8,37	9,50	13,75	18,90	19,91
δ_{V0}	Short term displacement:	[mm]	1,70	1,85	1,85	1,89	1,90	2,14	2,26	2,38	2,35
$\delta_{V\infty}$	Long term displacement:	[mm]	2,60	2,78	2,78	2,84	2,85	3,21	3,39	3,57	3,53
Displacements under shear loads in cracked concrete											
V	Service shear load:	[kN]	3,40	3,80	4,00	5,40	6,80	6,70	13,75	13,20	19,91
δ_{V0}	Short term displacement:	[mm]	1,72	1,80	1,81	1,84	1,87	1,95	2,25	2,16	2,35
$\delta_{V\infty}$	Long term displacement:	[mm]	2,58	2,70	2,72	2,76	2,81	2,93	3,38	3,24	3,53

TXE screw anchor	Annex C10
Performances	
Displacements under static or quasi-static tension and shear loads	



Table C10: Characteristic values for seismic performance category C1, carbon steel versions TH / TF / TN / TK / TG

Characteristic values for seismic performance category C1, carbon steel versions TH / TF / TN / TK / TG		Performances					
		6		8		10	
h_{nom}	Nominal embedment depth: [mm]	40	55	50	65	55	85
Resistance to steel failure under tension loads							
$N_{Rk,s,C1}$	Characteristic resistance: [kN]	25,12		39,14		54,81	
γ_{Ms}	Partial safety factor ¹⁾ : [-]	1,4					
Resistance to steel failure under shear loads							
$V_{Rk,s,C1}$	Characteristic resistance: [kN]	5,9	9,4	8,7	11,7	21,4	19,2
γ_{Ms}	Partial safety factor ¹⁾ : [-]	1,5					
α_{gap}	Factor for annular gap: [-]	0,5					
Resistance to pull-out failure							
$N_{Rk,p,C1}$	Characteristic resistance in cracked concrete: [kN]	5,0	5,0	6,2	8,8	6,5	14,7
γ_{inst}	Robustness: [-]	1,2	1,0	1,2	1,0	1,0	1,0
Resistance to concrete cone failure							
h_{ef}	Effective depth: [mm]	30,0	43,0	37,5	50,5	41,5	67,0
$s_{cr,N}$	Spacing: [mm]	3 x h_{ef}					
$c_{cr,N}$	Edge distance: [mm]	1,5 x h_{ef}					
γ_{inst}	Robustness: [-]	1,2	1,0	1,2	1,0	1,0	1,0

¹⁾ In absence of other national regulations

Characteristic values for seismic performance category C1, carbon steel versions TH / TF / TN / TK / TG		Performances							
		12		14		16		18	
h_{nom}	Nominal embedment depth: [mm]	75	105	115	80	120	140		
Resistance to steel failure under tension loads									
$N_{Rk,s,C1}$	Characteristic resistance: [kN]	74,48		105,45		124,41		161,56	
γ_{Ms}	Partial safety factor ¹⁾ : [-]	1,4							
Resistance to steel failure under shear loads									
$V_{Rk,s,C1}$	Characteristic resistance: [kN]	30,2	23,5	31,7	47,0	40,6	44,1		
γ_{Ms}	Partial safety factor ¹⁾ : [-]	1,5							
α_{gap}	Factor for annular gap: [-]	0,5							
Resistance to pull-out failure									
$N_{Rk,p,C1}$	Characteristic resistance in cracked concrete: [kN]	10,3	18,2	23,2	10,6	30,4	35,3		
γ_{inst}	Robustness: [-]	1,0							
Resistance to concrete cone failure									
h_{ef}	Effective depth: [mm]	58,0	83,5	92,0	58,0	92,0	112,0		
$s_{cr,N}$	Spacing: [mm]	3 x h_{ef}							
$c_{cr,N}$	Edge distance: [mm]	1,5 x h_{ef}							
γ_{inst}	Robustness: [-]	1,0							

¹⁾ In absence of other national regulations

THE screw anchor	Annex C11
Performances	
Characteristic values for seismic performance category C1	



Table C11: Characteristic values for seismic performance category C1, stainless steel version TX

Characteristic values for seismic performance category C1, stainless steel version TX		Performances							
		6		8		10		12	
h_{nom}	Nominal embedment depth: [mm]	40	55	50	65	55	85	75	105
Resistance to steel failure under tension loads									
$N_{Rk,s,C1}$	Characteristic resistance: [kN]	17,58		29,30		48,13		69,67	
γ_{Ms}	Partial safety factor ¹⁾ : [-]	1,5							
Resistance to steel failure under shear loads									
$V_{Rk,s,C1}$	Characteristic resistance: [kN]	5,83	8,44	8,04	10,00	15,16	19,86	25,96	30,80
γ_{Ms}	Partial safety factor ¹⁾ : [-]	1,25							
α_{gap}	Factor for annular gap: [-]	0,5							
Resistance to pull-out failure									
$N_{Rk,p,C1}$	Characteristic resistance in cracked concrete: [kN]	2,12	5,70	3,64	8,77	6,69	12,84	9,87	21,53
γ_{inst}	Robustness: [-]	1,2	1,2	1,2	1,2	1,2	1,2	1,2	1,0
Resistance to concrete cone failure									
h_{ef}	Effective depth: [mm]	30,0	43,0	37,5	50,5	41,5	67,0	58,0	83,5
$S_{cr,N}$	Spacing: [mm]	3 x h_{ef}							
$C_{cr,N}$	Edge distance: [mm]	1,5 x h_{ef}							
γ_{inst}	Robustness: [-]	1,2	1,2	1,2	1,2	1,2	1,2	1,2	1,0
Resistance to pry-out failure									
k_8	Pry-out factor: [-]	1,66	1,05	1,71	1,39	1,83	2,00	2,19	2,00
γ_{inst}	Robustness: [-]	1,0							
Resistance to concrete edge failure									
l_t	Effective length of fastener under shear loads: [mm]	30,0	43,0	37,5	50,5	41,5	67,0	58,0	83,5
d_{nom}	Outside fastener diameter: [mm]	6		8		10		12	
γ_{inst}	Robustness: [-]	1,0							

¹⁾ In absence of other national regulations

TXE screw anchor	Annex C12
Performances	
Characteristic values for seismic performance category C1	



Table C12: Characteristic values for seismic performance category C2, carbon steel versions TH / TF / TN / TK / TG

Characteristic values for seismic performance category C2, carbon steel versions TH / TF / TN / TK / TG			Performances						
			8	10	12	14	16	18	
h_{nom}	Nominal embedment depth:	[mm]	50	65	85	105	115	120	140
Resistance to steel failure under tension loads									
$N_{Rk,s,C2}$	Characteristic resistance:	[kN]	39,14	39,14	54,81	74,48	105,45	124,41	161,56
γ_{Ms}	Partial safety factor ¹⁾ :	[-]	1,4						
Resistance to steel failure under shear loads									
$V_{Rk,s,C2}$	Characteristic resistance:	[kN]	8,4	11,7	19,2	23,5	31,7	33,5	44,1
γ_{Ms}	Partial safety factor ¹⁾ :	[-]	1,5						
α_{gap}	Factor for annular gap:	[-]	0,5						
Resistance to pull-out failure									
$N_{Rk,p,C2}$	Characteristic resistance in cracked concrete:	[kN]	2,3	3,4	6,9	10,5	15,3	13,2	31,5
γ_{inst}	Robustness:	[-]	1,2	1,0	1,0	1,0	1,0	1,0	1,0
Resistance to concrete cone failure									
h_{ef}	Effective depth:	[mm]	37,5	50,5	67,0	83,5	92,0	92,0	112,0
$S_{cr,N}$	Spacing:	[mm]	3 x h_{ef}						
$C_{cr,N}$	Edge distance:	[mm]	1,5 x h_{ef}						
γ_{inst}	Robustness:	[-]	1,0						
Displacements									
$\delta_{N,C2}$ (DLS)	Displacement Damage	[mm]	0,36	0,16	0,22	0,41	0,25	0,58	0,66
$\delta_{V,C2}$ (DLS)	Limitation State: ²⁾	[mm]	1,60	0,79	1,13	1,69	1,52	6,83	1,69
$\delta_{N,C2}$ (ULS)	Displacement Ultimate	[mm]	1,08	2,70	3,11	2,61	2,32	2,02	1,89
$\delta_{V,C2}$ (ULS)	Limit State: ²⁾	[mm]	2,54	4,74	7,43	9,03	6,29	9,61	8,79
DLS	Damage Limitation State: see EN 1992-4, 2.2.1)								
ULS	Ultimate Limitation State: see EN 1992-4 2.2.1)								

¹⁾ In absence of other national regulations

²⁾ The listed displacements represent mean values

THE screw anchor

Performances

Characteristic values for seismic performance category C2

**Annex
C13**



Table C13: Characteristic values under fire exposure, carbon steel head styles E, K and J

Characteristic values under fire exposure, carbon steel head styles E, K and J				Performances							
				6			8		10		
h_{nom}	Nominal embedment depth:	[mm]		35	40	55	50	65	55	75	85
Fire resistance to steel failure											
$N_{Rk,s,fi}$	Characteristic tension resistance:	R30	[kN]	1,48			2,62		4,21		
		R60	[kN]	1,12			1,97		3,16		
		R90	[kN]	0,76			1,33		2,10		
		R120	[kN]	0,58			1,00		1,58		
$V_{Rk,s,fi}$	Characteristic shear resistance:	R30	[kN]	1,48			2,62		4,21		
		R60	[kN]	1,12			1,97		3,16		
		R90	[kN]	0,76			1,33		2,10		
		R120	[kN]	0,58			1,00		1,58		
$M^0_{Rk,s,fi}$	Characteristic bending resistance:	R30	[Nm]	1,27			2,94		5,90		
		R60	[Nm]	0,97			2,22		4,42		
		R90	[Nm]	0,66			1,49		2,94		
		R120	[Nm]	0,50			1,13		2,21		
Fire resistance to pull-out failure											
$N_{Rk,c,fi}$	Characteristic resistance:	R30 - R90	[kN]	1,14	1,41	2,43	1,98	3,09	2,30	3,85	4,72
		R120	[kN]	0,91	1,13	1,94	1,58	2,47	1,84	3,08	3,78
Fire resistance to concrete cone failure ¹⁾											
$N_{Rk,c,fi}$	Characteristic resistance:	R30 - R90	[kN]	0,59	0,85	2,09	1,48	3,12	1,91	4,51	6,33
		R120	[kN]	0,47	0,68	1,67	1,19	2,50	1,53	3,61	5,06
$Scr_{N,fi}$	Spacing:	R30 - R120	[mm]	4 x h_{ef}							
$S_{min,fi}$	Minimum spacing:	R30 - R120	[mm]	35		35		50			
$C_{cr,N,fi}$	Edge distance:	R30 - R120	[mm]	2 x h_{ef}							
$C_{min,fi}$	Minimum edge distance:	R30 - R120	[mm]	$C_{min} = 2 \times h_{ef}$; if fire attack comes from more than one side, the edge distance of the anchor has to be ≥ 300 mm							
Fire resistance to concrete pry-out failure											
k_8	Pry-out factor:	R30 - R120	[mm]	2,05	1,44	1,15	1,80	1,27	1,95	1,32	2,00

¹⁾ As a rule, splitting failure can be neglected since cracked concrete and reinforcement is assumed.
In absence of other national regulations the partial safety factor for resistance under fire exposure $\gamma_{m,fi} = 1,0$ is recommended

THE screw anchor	Annex C14
Performances	
Characteristic values under fire exposure	



Table C14: Characteristic values under fire exposure, carbon steel head styles E, K and J (cont)

Characteristic values under fire exposure, carbon steel head styles E, K and J			Performances							
			12		14		16		18	
h_{nom}	Nominal embedment depth:	[mm]	75	105	75	115	80	120	90	140
Fire resistance to steel failure										
$N_{Rk,s,fi}$	Characteristic tension resistance:	R30 [kN]	7,61		9,10		12,04		14,88	
		R60 [kN]	5,24		6,80		8,99		11,11	
		R90 [kN]	3,46		4,49		5,93		7,33	
		R120 [kN]	2,57		3,33		4,41		5,45	
$V_{Rk,s,fi}$	Characteristic shear resistance:	R30 [kN]	7,61		9,10		12,04		14,88	
		R60 [kN]	5,24		6,80		8,99		11,11	
		R90 [kN]	3,46		4,49		5,93		7,33	
		R120 [kN]	2,57		3,33		4,41		5,45	
$M^0_{Rk,s,fi}$	Characteristic bending resistance:	R30 [Nm]	11,96		18,12		27,56		38,52	
		R60 [Nm]	8,93		13,53		20,57		28,75	
		R90 [Nm]	5,90		8,93		13,59		18,99	
		R120 [Nm]	4,38		6,63		10,09		14,10	
Fire resistance to pull-out failure										
$N_{Rk,p,fi}$	Characteristic resistance:	R30 - R90 [kN]	3,80	6,57	3,80	7,60	3,80	7,60	4,99	10,20
		R120 [kN]	3,04	5,25	3,04	6,08	3,04	6,08	3,99	8,16
Fire resistance to concrete cone failure ¹⁾										
$N_{Rk,c,fi}$	Characteristic resistance:	R30 - R90 [kN]	4,41	10,97	4,41	13,98	4,41	13,98	6,93	22,86
		R120 [kN]	3,53	8,78	3,53	11,18	3,53	11,18	5,55	18,29
$S_{cr,N,fi}$	Spacing:	R30 - R120 [mm]	4 x h_{ef}							
$S_{min,fi}$	Minimum spacing:	R30 - R120 [mm]	75		80		80		90	
$C_{cr,N,fi}$	Edge distance:	R30 - R120 [mm]	2 x h_{ef}							
$C_{min,fi}$	Minimum edge distance:	R30 - R120 [mm]	$C_{min} = 2 \times h_{ef}$; if fire attack comes from more than one side, the edge distance of the anchor has to be ≥ 300 mm							
Fire resistance to concrete pry-out failure										
k_8	Pry-out factor:	R30 - R120 [mm]	2,33	2,00	2,55	2,00	2,14	2,00	2,66	2,00

¹⁾ As a rule, splitting failure can be neglected since cracked concrete and reinforcement is assumed.

In absence of other national regulations the partial safety factor for resistance under fire exposure $\gamma_{m,fi} = 1,0$ is recommended

THE screw anchor	Annex C15
Performances	
Characteristic values under fire exposure	



Table C15: Characteristic values under fire exposure, carbon steel head styles N, A, W and S

Characteristic values under fire exposure, carbon steel head styles N, A, W and S				Performances							
				6			8		10		
h_{nom}	Nominal embedment depth:	[mm]		35	40	55	50	65	55	75	85
Fire resistance to steel failure											
$N_{Rk,s,fi}$	Characteristic tension resistance:	R30	[kN]		0,26			0,45			1,07
		R60	[kN]		0,23			0,41			0,93
		R90	[kN]		0,18			0,32			0,71
		R120	[kN]		0,13			0,23			0,57
$V_{Rk,s,fi}$	Characteristic shear resistance:	R30	[kN]		0,26			0,45			1,07
		R60	[kN]		0,23			0,41			0,93
		R90	[kN]		0,18			0,32			0,71
		R120	[kN]		0,13			0,23			0,57
$M^0_{Rk,s,fi}$	Characteristic bending resistance:	R30	[Nm]		0,22			0,52			1,52
		R60	[Nm]		0,20			0,46			1,32
		R90	[Nm]		0,16			0,36			1,02
		R120	[Nm]		0,11			0,26			0,81
Fire resistance to pull-out failure											
$N_{Rk,c,fi}$	Characteristic resistance:	R30 - R90	[kN]	1,14	1,41	2,43	1,98	3,09	2,30	3,85	4,72
		R120	[kN]	0,91	1,13	1,94	1,58	2,47	1,84	3,08	3,78
Fire resistance to concrete cone failure ¹⁾											
$N_{Rk,c,fi}$	Characteristic resistance:	R30 - R90	[kN]	0,59	0,85	2,09	1,48	3,12	1,91	4,51	6,33
		R120	[kN]	0,47	0,68	1,67	1,19	2,50	1,53	3,61	5,06
$S_{cr,N,fi}$	Spacing:	R30 - R120	[mm]	4 x h_{ef}							
$S_{min,fi}$	Minimum spacing:	R30 - R120	[mm]	35			35		50		
$C_{cr,N,fi}$	Edge distance:	R30 - R120	[mm]	2 x h_{ef}							
$C_{min,fi}$	Minimum edge distance:	R30 - R120	[mm]	$C_{min} = 2 \times h_{ef}$; if fire attack comes from more than one side, the edge distance of the anchor has to be ≥ 300 mm							
Fire resistance to concrete pry-out failure											
k_8	Pry-out factor:	R30 - R120	[mm]	2,05	1,44	1,15	1,80	1,27	1,95	1,32	2,00

¹⁾ As a rule, splitting failure can be neglected since cracked concrete and reinforcement is assumed.
In absence of other national regulations the partial safety factor for resistance under fire exposure $\gamma_{m,fi} = 1,0$ is recommended

THE screw anchor	Annex C16
Performances	
Characteristic values under fire exposure	



Table C16: Characteristic values under fire exposure, carbon steel head styles N, A, W and S (cont)

Characteristic values under fire exposure, carbon steel head styles N, A, W and S			Performances							
			12		14		16		18	
h_{nom}	Nominal embedment depth:	[mm]	75	105	75	115	80	120	90	140
Fire resistance to steel failure										
$N_{Rk,s,fi}$	Characteristic tension resistance:	R30 [kN]	2,01		2,99		3,53		4,74	
		R60 [kN]	1,51		2,24		2,65		3,56	
		R90 [kN]	1,31		1,94		2,29		3,08	
		R120 [kN]	1,01		1,50		1,76		2,37	
$V_{Rk,s,fi}$	Characteristic shear resistance:	R30 [kN]	2,01		2,99		3,53		4,74	
		R60 [kN]	1,51		2,24		2,65		3,56	
		R90 [kN]	1,31		1,94		2,29		3,08	
		R120 [kN]	1,01		1,50		1,76		2,37	
$M^0_{Rk,s,fi}$	Characteristic bending resistance:	R30 [Nm]	3,42		6,19		7,94		12,37	
		R60 [Nm]	2,56		4,64		5,95		9,28	
		R90 [Nm]	2,22		4,02		5,16		8,04	
		R120 [Nm]	1,71		3,10		3,97		6,18	
Fire resistance to pull-out failure										
$N_{Rk,p,fi}$	Characteristic resistance:	R30-R90 [kN]	3,80	6,57	3,80	7,60	3,80	7,60	4,99	10,20
		R120 [kN]	3,04	5,25	3,04	6,08	3,04	6,08	3,99	8,16
Fire resistance to concrete cone failure ¹⁾										
$N_{Rk,c,fi}$	Characteristic resistance:	R30 - R90 [kN]	4,41	10,97	4,41	13,98	4,41	13,98	6,93	22,86
		R120 [kN]	3,53	8,78	3,53	11,18	3,53	11,18	5,55	18,29
$S_{cr,N,fi}$	Spacing:	R30 - R120 [mm]	4 x h_{ef}							
$S_{min,fi}$	Minimum spacing:	R30 - R120 [mm]	75		80		80		90	
$C_{cr,N,fi}$	Edge distance:	R30 - R120 [mm]	2 x h_{ef}							
$C_{min,fi}$	Minimum edge distance:	R30 - R120 [mm]	$C_{min} = 2 \times h_{ef}$; if fire attack comes from more than one side, the edge distance of the anchor has to be ≥ 300 mm							
Fire resistance to concrete pry-out failure										
k_8	Pry-out factor:	R30 - R120 [mm]	2,33	2,00	2,55	2,00	2,14	2,00	2,66	2,00

¹⁾ As a rule, splitting failure can be neglected since cracked concrete and reinforcement is assumed.
In absence of other national regulations the partial safety factor for resistance under fire exposure $\gamma_{m,fi} = 1,0$ is recommended

THE screw anchor

Performances

Characteristic values under fire exposure

Annex C17



Table C17: Characteristic values under fire exposure, carbon steel head style P

Characteristic values under fire exposure, carbon steel head style P			Performances				
			6			8	
h_{nom}	Nominal embedment depth:	[mm]	35	40	55	50	65
Fire resistance to steel failure							
$N_{Rk,s,fi}$	Characteristic tension resistance:	R30 [kN]	0,87			2,76	
		R60 [kN]	0,59			2,06	
		R90 [kN]	0,30			1,35	
		R120 [kN]	0,16			1,00	
$V_{Rk,s,fi}$	Characteristic shear resistance:	R30 [kN]	0,87			2,76	
		R60 [kN]	0,59			2,06	
		R90 [kN]	0,30			1,35	
		R120 [kN]	0,16			1,00	
$M^0_{Rk,s,fi}$	Characteristic bending resistance:	R30 [Nm]	0,75			3,11	
		R60 [Nm]	0,51			2,31	
		R90 [Nm]	0,26			1,52	
		R120 [Nm]	0,14			1,12	
Fire resistance to pull-out failure							
$N_{Rk,c,fi}$	Characteristic resistance:	R30 - R90 [kN]	1,14	1,41	2,43	1,98	3,09
		R120 [kN]	0,91	1,13	1,94	1,58	2,47
Fire resistance to concrete cone failure ¹⁾							
$N_{Rk,c,fi}$	Characteristic resistance:	R30 - R90 [kN]	0,59	0,85	2,09	1,48	3,12
		R120 [kN]	0,47	0,68	1,67	1,19	2,50
$s_{cr,N,fi}$	Spacing:	R30 - R120 [mm]	4 x h_{ef}				
$s_{min,fi}$	Minimum spacing:	R30 - R120 [mm]	35		35		
$c_{cr,N,fi}$	Edge distance:	R30 - R120 [mm]	2 x h_{ef}				
$c_{min,fi}$	Minimum edge distance:	R30 - R120 [mm]	$c_{min} = 2 \times h_{ef}$; if fire attack comes from more than one side, the edge distance of the anchor has to be ≥ 300 mm				
Fire resistance to concrete pry-out failure							
k_8	Pry-out factor:	R30 - R120 [mm]	2,05	1,44	1,15	1,80	1,27

²⁾ As a rule, splitting failure can be neglected since cracked concrete and reinforcement is assumed.

In absence of other national regulations the partial safety factor for resistance under fire exposure $\gamma_{m,fi} = 1,0$ is recommended

THE screw anchor	Annex C18
Performances	
Characteristic values under fire exposure	



Table C18: Characteristic values under fire exposure, carbon steel head style T

Characteristic values under fire exposure, carbon steel head style T			Performances		
			6		
h_{nom}	Nominal embedment depth:	[mm]	35	40	55
Fire resistance to steel failure					
$N_{Rk,s,fi}$	Characteristic tension resistance:	R30 [kN]	1,62		
		R60 [kN]	1,14		
		R90 [kN]	0,67		
		R120 [kN]	0,43		
$V_{Rk,s,fi}$	Characteristic shear resistance:	R30 [kN]	1,62		
		R60 [kN]	1,14		
		R90 [kN]	0,67		
		R120 [kN]	0,43		
$M^0_{Rk,s,fi}$	Characteristic bending resistance:	R30 [Nm]	1,40		
		R60 [Nm]	0,99		
		R90 [Nm]	0,58		
		R120 [Nm]	0,37		
Fire resistance to pull-out failure					
$N_{Rk,c,fi}$	Characteristic resistance:	R30 - R90 [kN]	1,14	1,41	2,43
		R120 [kN]	0,91	1,13	1,94
Fire resistance to concrete cone failure ¹⁾					
$N_{Rk,c,fi}$	Characteristic resistance:	R30 - R90 [kN]	0,59	0,85	2,09
		R120 [kN]	0,47	0,68	1,67
$S_{cr,N,fi}$	Spacing:	R30 - R120 [mm]	4 x h_{ef}		
$S_{min,fi}$	Minimum spacing:	R30 - R120 [mm]	35		
$C_{cr,N,fi}$	Edge distance:	R30 - R120 [mm]	2 x h_{ef}		
$C_{min,fi}$	Minimum edge distance:	R30 - R120 [mm]	$C_{min} = 2 \times h_{ef}$; if fire attack comes from more than one side, the edge distance of the anchor has to be ≥ 300 mm		
Fire resistance to concrete pry-out failure					
k_8	Pry-out factor:	R30 - R120 [mm]	2,05	1,44	1,15

¹⁾ As a rule, splitting failure can be neglected since cracked concrete and reinforcement is assumed.
In absence of other national regulations the partial safety factor for resistance under fire exposure $\gamma_{m,fi} = 1,0$ is recommended

THE screw anchor	Annex C19
Performances	
Characteristic values under fire exposure	



Table C19: Characteristic values under fire exposure, carbon steel head style M

Characteristic values under fire exposure, carbon steel head style M			Performances				
			6			8	
h_{nom}	Nominal embedment depth:	[mm]	35	40	55	50	60
Fire resistance to steel failure							
$N_{Rk,s,fi}$	Characteristic tension resistance:	R30 [kN]	0,87			0,87	
		R60 [kN]	0,72			0,72	
		R90 [kN]	0,58			0,58	
		R120 [kN]	0,51			0,51	
$V_{Rk,s,fi}$	Characteristic shear resistance:	R30 [kN]	0,87			0,87	
		R60 [kN]	0,72			0,72	
		R90 [kN]	0,58			0,58	
		R120 [kN]	0,51			0,51	
$M^0_{Rk,s,fi}$	Characteristic bending resistance:	R30 [Nm]	0,75			0,75	
		R60 [Nm]	0,62			0,62	
		R90 [Nm]	0,50			0,50	
		R120 [Nm]	0,44			0,44	
Fire resistance to pull-out failure							
$N_{Rk,c,fi}$	Characteristic resistance:	R30 - R90 [kN]	1,14	1,41	2,43	1,98	3,09
		R120 [kN]	0,91	1,13	1,94	1,58	2,47
Fire resistance to concrete cone failure ¹⁾							
$N_{Rk,c,fi}$	Characteristic resistance:	R30 - R90 [kN]	0,59	0,85	2,09	1,48	3,12
		R120 [kN]	0,47	0,68	1,67	1,19	2,50
$S_{cr,N,fi}$	Spacing:	R30 - R120 [mm]	4 x h_{ef}				
$S_{min,fi}$	Minimum spacing:	R30 - R120 [mm]	35			35	
$C_{cr,N,fi}$	Edge distance:	R30 - R120 [mm]	2 x h_{ef}				
$C_{min,fi}$	Minimum edge distance:	R30 - R120 [mm]	$C_{min} = 2 \times h_{ef}$; if fire attack comes from more than one side, the edge distance of the anchor has to be ≥ 300 mm				
Fire resistance to concrete pry-out failure							
k_8	Pry-out factor:	R30 - R120 [mm]	2,05	1,44	1,15	1,80	1,27

¹⁾ As a rule, splitting failure can be neglected since cracked concrete and reinforcement is assumed.
In absence of other national regulations the partial safety factor for resistance under fire exposure $\gamma_{m,fi} = 1,0$ is recommended

THE screw anchor	Annex C20
Performances	
Characteristic values under fire exposure	



Table C20: Characteristic values under fire exposure, carbon steel head style F

Characteristic values under fire exposure, carbon steel head style F			Performances				
			6			8	
	Inner thread	[-]	M8/M10	M10	M8/M10	M10; M12	
h_{nom}	Nominal embedment depth:	[mm]	35	40	55	50	65
Fire resistance to steel failure							
$N_{Rk,s,fi}$	Characteristic tension resistance:	R30 [kN]	0,66	1,01	0,66	1,44	
		R60 [kN]	0,56	0,83	0,56	1,07	
		R90 [kN]	0,46	0,65	0,46	0,70	
		R120 [kN]	0,41	0,57	0,41	0,51	
$V_{Rk,s,fi}$	Characteristic shear resistance:	R30 [kN]	0,66	1,01	0,66	1,44	
		R60 [kN]	0,56	0,83	0,56	1,07	
		R90 [kN]	0,46	0,65	0,46	0,70	
		R120 [kN]	0,41	0,57	0,41	0,51	
$M^0_{Rk,s,fi}$	Characteristic bending resistance:	R30 [Nm]	0,57	0,87	0,57	1,62	
		R60 [Nm]	0,48	0,72	0,48	1,20	
		R90 [Nm]	0,40	0,56	0,40	0,78	
		R120 [Nm]	0,35	0,49	0,35	0,57	
Fire resistance to pull-out failure							
$N_{Rk,c,fi}$	Characteristic resistance:	R30 - R90 [kN]	1,14	1,41	2,43	1,98	3,09
		R120 [kN]	0,91	1,13	1,94	1,58	2,47
Fire resistance to concrete cone failure ¹⁾							
$N_{Rk,c,fi}$	Characteristic resistance:	R30 - R90 [kN]	0,59	0,85	2,09	1,48	3,12
		R120 [kN]	0,47	0,68	1,67	1,19	2,50
$S_{cr,N,fi}$	Spacing:	R30 - R120 [mm]	4 x h_{ef}				
$S_{min,fi}$	Minimum spacing:	R30 - R120 [mm]	35			35	
$C_{cr,N,fi}$	Edge distance:	R30 - R120 [mm]	2 x h_{ef}				
$C_{min,fi}$	Minimum edge distance:	R30 - R120 [mm]	$C_{min} = 2 \times h_{ef}$; if fire attack comes from more than one side, the edge distance of the anchor has to be ≥ 300 mm				
Fire resistance to concrete pry-out failure							
k_8	Pry-out factor:	R30 - R120 [mm]	2,05	1,44	1,15	1,80	1,27

¹⁾ As a rule, splitting failure can be neglected since cracked concrete and reinforcement is assumed.
In absence of other national regulations the partial safety factor for resistance under fire exposure $\gamma_{m,fi} = 1,0$ is recommended

THE screw anchor	Annex C21
Performances	
Characteristic values under fire exposure	



Table C21: Characteristic values under fire exposure, stainless steel head styles E, K and J

Characteristic values fire exposure, stainless steel head styles E, K and J			Performances								
			6			8		10		12	
h_{nom}	Nominal embedment depth:	[mm]	35	40	55	50	65	55	85	75	105
Fire resistance to steel failure											
$N_{Rk,s,fi}$	Characteristic tension resistance:	R30 [kN]	1,48			2,62		4,21		7,61	
		R60 [kN]	1,12			1,97		3,16		5,24	
		R90 [kN]	0,76			1,33		2,10		3,46	
		R120 [kN]	0,58			1,00		1,58		2,57	
$V_{Rk,s,fi}$	Characteristic shear resistance:	R30 [kN]	1,48			2,62		4,21		7,61	
		R60 [kN]	1,12			1,97		3,16		5,24	
		R90 [kN]	0,76			1,33		2,10		3,46	
		R120 [kN]	0,58			1,00		1,58		2,57	
$M^0_{Rk,s,fi}$	Characteristic bending resistance:	R30 [Nm]	1,27			2,94		5,90		11,96	
		R60 [Nm]	0,97			2,22		4,42		8,93	
		R90 [Nm]	0,66			1,49		2,94		5,90	
		R120 [Nm]	0,50			1,13		2,21		4,38	
Fire resistance to pull-out failure											
$N_{Rkp,fi}$	Characteristic resistance:	R30-R90 [kN]	0,25	0,63	1,88	1,25	3,09	2,30	4,72	3,50	6,57
		R120 [kN]	0,20	0,50	1,50	1,00	2,47	1,84	3,78	2,80	5,25
Fire resistance to concrete cone failure ¹⁾											
$N_{Rk,c,fi}$	Characteristic resistance:	R30-R90 [kN]	0,59	0,85	2,09	1,48	3,12	1,91	6,33	4,41	10,97
		R120 [kN]	0,47	0,68	1,67	1,19	2,50	1,53	5,06	3,53	8,78
$S_{cr,N,fi}$	Spacing:	R30 - R120 [mm]	4 x h_{ef}								
$S_{min,fi}$	Minimum spacing:	R30 - R120 [mm]	35			35		50		75	
$C_{cr,N,fi}$	Edge distance:	R30 - R120 [mm]	2 x h_{ef}								
$C_{min,fi}$	Minimum edge distance:	R30 - R120 [mm]	$C_{min} = 2 \times h_{ef}$; if fire attack comes from more than one side, the edge distance of the anchor has to be ≥ 300 mm								
Fire resistance to concrete pry-out failure											
k_8	Pry-out factor:	R30 - R120 [mm]	1,87	1,66	1,05	1,71	1,39	1,83	2,00	2,19	2,00

¹⁾ As a rule, splitting failure can be neglected since cracked concrete and reinforcement is assumed.
In absence of other national regulations the partial safety factor for resistance under fire exposure $\gamma_{m,fi} = 1,0$ is recommended

TXE screw anchor	Annex C22
Performances	
Characteristic values under fire exposure	



Table C22: Characteristic values under fire exposure, stainless steel head styles N, A, W and S												
Characteristic values fire exposure, stainless steel head styles A, N, W and S			Performances									
			6			8			10		12	
h_{nom}	Nominal embedment depth:	[mm]	35	40	55	50	65	55	85	75	105	
Fire resistance to steel failure												
$N_{Rk,s,fi}$	Characteristic tension resistance:	R30 [kN]	0,24			0,79			1,64		2,95	
		R60 [kN]	0,22			0,63			1,31		2,45	
		R90 [kN]	0,17			0,48			1,05		1,96	
		R120 [kN]	0,12			0,40			0,92		1,57	
$V_{Rk,s,fi}$	Characteristic shear resistance:	R30 [kN]	0,24			0,79			1,64		2,95	
		R60 [kN]	0,22			0,63			1,31		2,45	
		R90 [kN]	0,17			0,48			1,05		1,96	
		R120 [kN]	0,12			0,40			0,92		1,57	
$M^0_{Rk,s,fi}$	Characteristic bending resistance:	R30 [Nm]	0,20			0,84			2,24		4,94	
		R60 [Nm]	0,18			0,67			1,79		4,12	
		R90 [Nm]	0,14			0,51			1,43		3,29	
		R120 [Nm]	0,10			0,42			1,26		2,63	
Fire resistance to pull-out failure												
$N_{Rk,p,fi}$	Characteristic resistance:	R30-R90 [kN]	0,25	0,63	1,88	1,25	3,09	2,30	4,72	3,50	6,57	
		R120 [kN]	0,20	0,50	1,50	1,00	2,47	1,84	3,78	2,80	5,25	
Fire resistance to concrete cone failure ¹⁾												
$N_{Rk,c,fi}$	Characteristic resistance:	R30-R90 [kN]	0,59	0,85	2,09	1,48	3,12	1,91	6,33	4,41	10,97	
		R120 [kN]	0,47	0,68	1,67	1,19	2,50	1,53	5,06	3,53	8,78	
$S_{cr,N,fi}$	Spacing:	R30 - R120 [mm]	4 x h_{ef}									
$S_{min,fi}$	Minimum spacing:	R30 - R120 [mm]	35			35			50		75	
$C_{cr,N,fi}$	Edge distance:	R30 - R120 [mm]	2 x h_{ef}									
$C_{min,fi}$	Minimum edge distance:	R30 - R120 [mm]	$C_{min} = 2 \times h_{ef}$; if fire attack comes from more than one side, the edge distance of the anchor has to be ≥ 300 mm									
Fire resistance to concrete pry-out failure												
k_8	Pry-out factor:	R30 - R120 [mm]	1,87	1,66	1,05	1,71	1,39	1,83	2,00	2,19	2,00	
¹⁾ As a rule, splitting failure can be neglected since cracked concrete and reinforcement is assumed. In absence of other national regulations the partial safety factor for resistance under fire exposure $\gamma_{m,fi} = 1,0$ is recommended												
TXE screw anchor										Annex C23		
Performances												
Characteristic values under fire exposure												



Table C23: Characteristic values under fire exposure, stainless steel head style P

Characteristic values under fire exposure, stainless steel head style P			Performances				
			6			8	
h_{nom}	Nominal embedment depth:	[mm]	35	40	55	50	65
Fire resistance to steel failure							
$N_{Rk,s,fi}$	Characteristic tension resistance:	R30 [kN]	0,87			2,76	
		R60 [kN]	0,59			2,06	
		R90 [kN]	0,30			1,35	
		R120 [kN]	0,16			1,00	
$V_{Rk,s,fi}$	Characteristic shear resistance:	R30 [kN]	0,87			2,76	
		R60 [kN]	0,59			2,06	
		R90 [kN]	0,30			1,35	
		R120 [kN]	0,16			1,00	
$M^0_{Rk,s,fi}$	Characteristic bending resistance:	R30 [Nm]	0,75			3,11	
		R60 [Nm]	0,51			2,31	
		R90 [Nm]	0,26			1,52	
		R120 [Nm]	0,14			1,12	
Fire resistance to pull-out failure							
$N_{Rk,p,fi}$	Characteristic resistance:	R30-R90 [kN]	0,25	0,63	1,88	1,25	3,09
		R120 [kN]	0,20	0,50	1,50	1,00	2,47
Fire resistance to concrete cone failure ¹⁾							
$N_{Rk,c,fi}$	Characteristic resistance:	R30-R90 [kN]	0,59	0,85	2,09	1,48	3,12
		R120 [kN]	0,47	0,68	1,67	1,19	2,50
$s_{cr,N,fi}$	Spacing:	R30 - R120 [mm]	4 x h_{ef}				
$s_{min,fi}$	Minimum spacing:	R30 - R120 [mm]	35		35		
$c_{cr,N,fi}$	Edge distance:	R30 - R120 [mm]	2 x h_{ef}				
$c_{min,fi}$	Minimum edge distance:	R30 - R120 [mm]	$c_{min} = 2 \times h_{ef}$; if fire attack comes from more than one side, the edge distance of the anchor has to be ≥ 300 mm				
Fire resistance to concrete pry-out failure							
k_8	Pry-out factor:	R30 - R120 [mm]	1,87	1,66	1,05	1,71	1,39

¹⁾ As a rule, splitting failure can be neglected since cracked concrete and reinforcement is assumed.

In absence of other national regulations the partial safety factor for resistance under fire exposure $\gamma_{m,fi} = 1,0$ is recommended

TXE screw anchor	Annex C24
Performances	
Characteristic values under fire exposure	



Table C24: Characteristic values under fire exposure, stainless steel head style T

Characteristic values under fire exposure, stainless steel head style T			Performances		
			6		
h_{nom}	Nominal embedment depth:	[mm]	35	40	55
Fire resistance to steel failure					
$N_{Rk,s,fi}$	Characteristic tension resistance:	R30 [kN]	1,62		
		R60 [kN]	1,14		
		R90 [kN]	0,67		
		R120 [kN]	0,43		
$V_{Rk,s,fi}$	Characteristic shear resistance:	R30 [kN]	1,62		
		R60 [kN]	1,14		
		R90 [kN]	0,67		
		R120 [kN]	0,43		
$M^0_{Rk,s,fi}$	Characteristic bending resistance:	R30 [Nm]	1,40		
		R60 [Nm]	0,99		
		R90 [Nm]	0,58		
		R120 [Nm]	0,37		
Fire resistance to pull-out failure					
$N_{Rk,p,fi}$	Characteristic resistance:	R30-R90 [kN]	0,25	0,63	1,88
		R120 [kN]	0,20	0,50	1,50
Fire resistance to concrete cone failure ¹⁾					
$N_{Rk,c,fi}$	Characteristic resistance:	R30-R90 [kN]	0,59	0,85	2,09
		R120 [kN]	0,47	0,68	1,67
$S_{cr,N,fi}$	Spacing:	R30 - R120 [mm]	4 x h_{ef}		
$S_{min,fi}$	Minimum spacing:	R30 - R120 [mm]	35		
$C_{cr,N,fi}$	Edge distance:	R30 - R120 [mm]	2 x h_{ef}		
$C_{min,fi}$	Minimum edge distance:	R30 - R120 [mm]	$C_{min} = 2 \times h_{ef}$; if fire attack comes from more than one side, the edge distance of the anchor has to be ≥ 300 mm		
Fire resistance to concrete pry-out failure					
k_8	Pry-out factor:	R30 - R120 [mm]	1,87	1,66	1,05

¹⁾ As a rule, splitting failure can be neglected since cracked concrete and reinforcement is assumed.

In absence of other national regulations the partial safety factor for resistance under fire exposure $\gamma_{m,fi} = 1,0$ is recommended

TXE screw anchor	Annex C25
Performances	
Characteristic values under fire exposure	



Table C25: Characteristic values under fire exposure, stainless steel head style M

Characteristic values under fire exposure, stainless steel head style M				Performances				
				6			8	
h_{nom}	Nominal embedment depth:	[mm]		35	40	55	50	65
Fire resistance to steel failure								
$N_{Rk,s,fi}$	Characteristic tension resistance:	R30	[kN]	0,87			0,87	
		R60	[kN]	0,72			0,72	
		R90	[kN]	0,58			0,58	
		R120	[kN]	0,51			0,51	
$V_{Rk,s,fi}$	Characteristic shear resistance:	R30	[kN]	0,87			0,87	
		R60	[kN]	0,72			0,72	
		R90	[kN]	0,58			0,58	
		R120	[kN]	0,51			0,51	
$M^0_{Rk,s,fi}$	Characteristic bending resistance:	R30	[Nm]	0,75			0,75	
		R60	[Nm]	0,62			0,62	
		R90	[Nm]	0,50			0,50	
		R120	[Nm]	0,44			0,44	
Fire resistance to pull-out failure								
$N_{Rk,p,fi}$	Characteristic resistance:	R30-R90	[kN]	0,25	0,63	1,88	1,25	3,09
		R120	[kN]	0,20	0,50	1,50	1,00	2,47
Fire resistance to concrete cone failure ¹⁾								
$N_{Rk,c,fi}$	Characteristic resistance:	R30-R90	[kN]	0,59	0,85	2,09	1,48	3,12
		R120	[kN]	0,47	0,68	1,67	1,19	2,50
$s_{cr,N,fi}$	Spacing:	R30 - R120	[mm]	4 x h_{ef}				
$s_{min,fi}$	Minimum spacing:	R30 - R120	[mm]	35			35	
$c_{cr,N,fi}$	Edge distance:	R30 - R120	[mm]	2 x h_{ef}				
$c_{min,fi}$	Minimum edge distance:	R30 - R120	[mm]	$c_{min} = 2 \times h_{ef}$; if fire attack comes from more than one side, the edge distance of the anchor has to be ≥ 300 mm				
Fire resistance to concrete pry-out failure								
k_8	Pry-out factor:	R30 - R120	[mm]	1,87	1,66	1,05	1,71	1,39

¹⁾ As a rule, splitting failure can be neglected since cracked concrete and reinforcement is assumed.
In absence of other national regulations the partial safety factor for resistance under fire exposure $\gamma_{m,fi}$ = 1,0 is recommended

TXE screw anchor	Annex C26
Performances	
Characteristic values under fire exposure	



Table C26: Characteristic values under fire exposure, stainless steel head style F

Characteristic values under fire exposure, stainless steel head style F			Performances				
			6			8	
	Inner thread	[-]	M8/M10	M10	M8/M10	M10; M12	
h_{nom}	Nominal embedment depth:	[mm]	35	40	55	50	65
Fire resistance to steel failure							
$N_{Rk,s,fi}$	Characteristic tension resistance:	R30 [kN]	0,66	1,01	0,66	1,44	
		R60 [kN]	0,56	0,83	0,56	1,07	
		R90 [kN]	0,46	0,65	0,46	0,70	
		R120 [kN]	0,41	0,57	0,41	0,51	
$V_{Rk,s,fi}$	Characteristic shear resistance:	R30 [kN]	0,66	1,01	0,66	1,44	
		R60 [kN]	0,56	0,83	0,56	1,07	
		R90 [kN]	0,46	0,65	0,46	0,70	
		R120 [kN]	0,41	0,57	0,41	0,51	
$M^0_{Rk,s,fi}$	Characteristic bending resistance:	R30 [Nm]	0,57	0,87	0,57	1,62	
		R60 [Nm]	0,48	0,72	0,48	1,20	
		R90 [Nm]	0,40	0,56	0,40	0,78	
		R120 [Nm]	0,35	0,49	0,35	0,57	
Fire resistance to pull-out failure							
$N_{Rk,c,fi}$	Characteristic resistance:	R30 - R90 [kN]	0,25	0,63	1,88	1,25	3,09
		R120 [kN]	0,20	0,50	1,50	1,00	2,47
Fire resistance to concrete cone failure ¹⁾							
$N_{Rk,c,fi}$	Characteristic resistance:	R30 - R90 [kN]	0,59	0,85	2,09	1,48	3,12
		R120 [kN]	0,47	0,68	1,67	1,19	2,50
Scr,N,fi	Spacing:	R30 - R120 [mm]	4 x h_{ef}				
$S_{min,fi}$	Minimum spacing:	R30 - R120 [mm]	35			35	
Cor,N,fi	Edge distance:	R30 - R120 [mm]	2 x h_{ef}				
$C_{min,fi}$	Minimum edge distance:	R30 - R120 [mm]	$C_{min} = 2 \times h_{ef}$; if fire attack comes from more than one side, the edge distance of the anchor has to be ≥ 300 mm				
Fire resistance to concrete pry-out failure							
k_8	Pry-out factor:	R30 - R120 [mm]	1,87	1,66	1,05	1,71	1,39

¹⁾ As a rule, splitting failure can be neglected since cracked concrete and reinforcement is assumed. In absence of other national regulations the partial safety factor for resistance under fire exposure $\gamma_{m,fi} = 1,0$ is recommended

TXE screw anchor	Annex C27
Performances	
Characteristic values under fire exposure	

